

**IMPORTANT
RETAIN FOR FUTURE REFERENCE
READ CAREFULLY**

Silver Cross[®]

St Ives

Cot bed

** IMPORTANT: THE ASSEMBLY OF THIS
PRODUCT REQUIRES TWO PEOPLE**

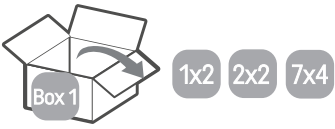

Parts list:

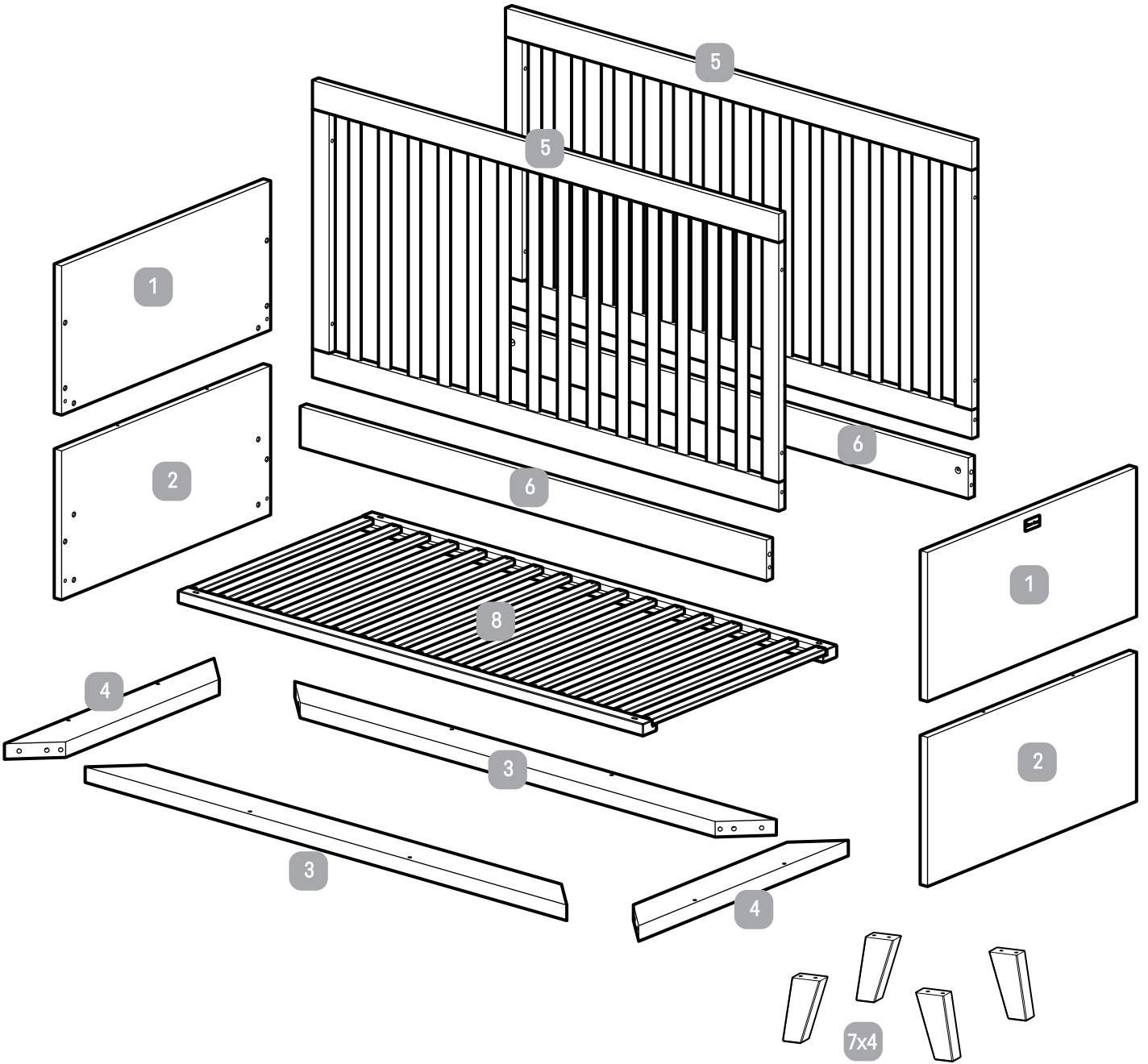

Fittings list:

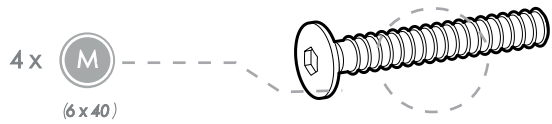
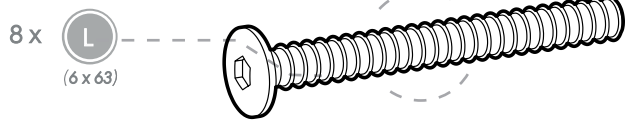
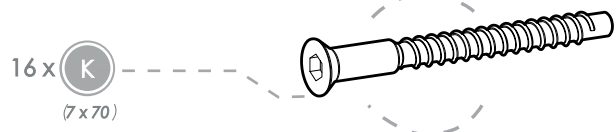
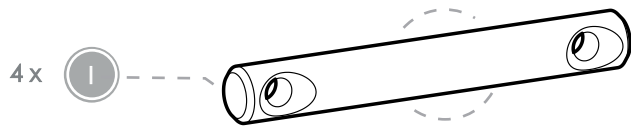
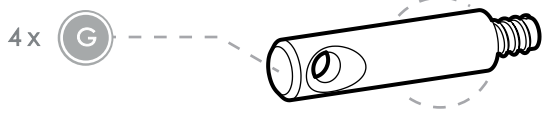
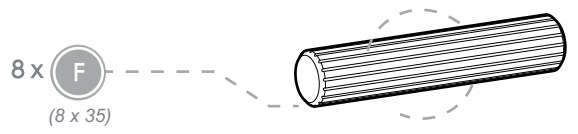
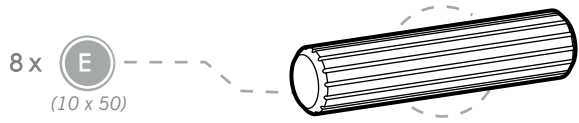
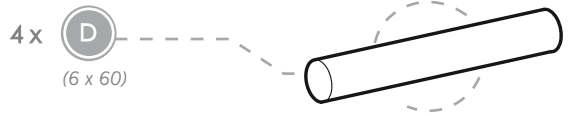
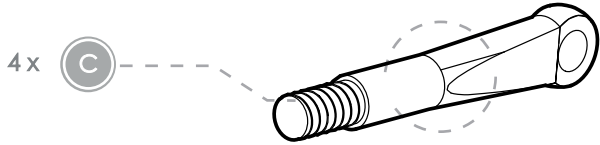
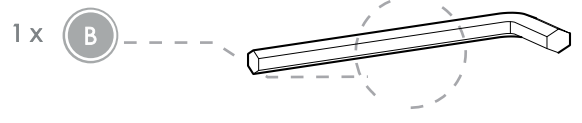
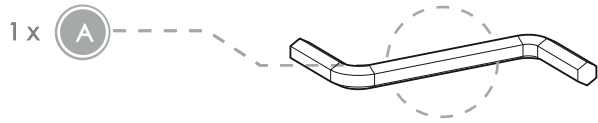

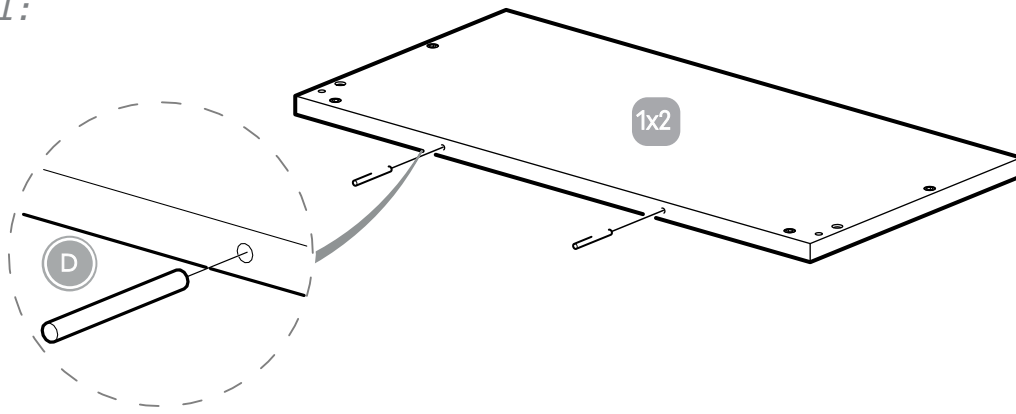
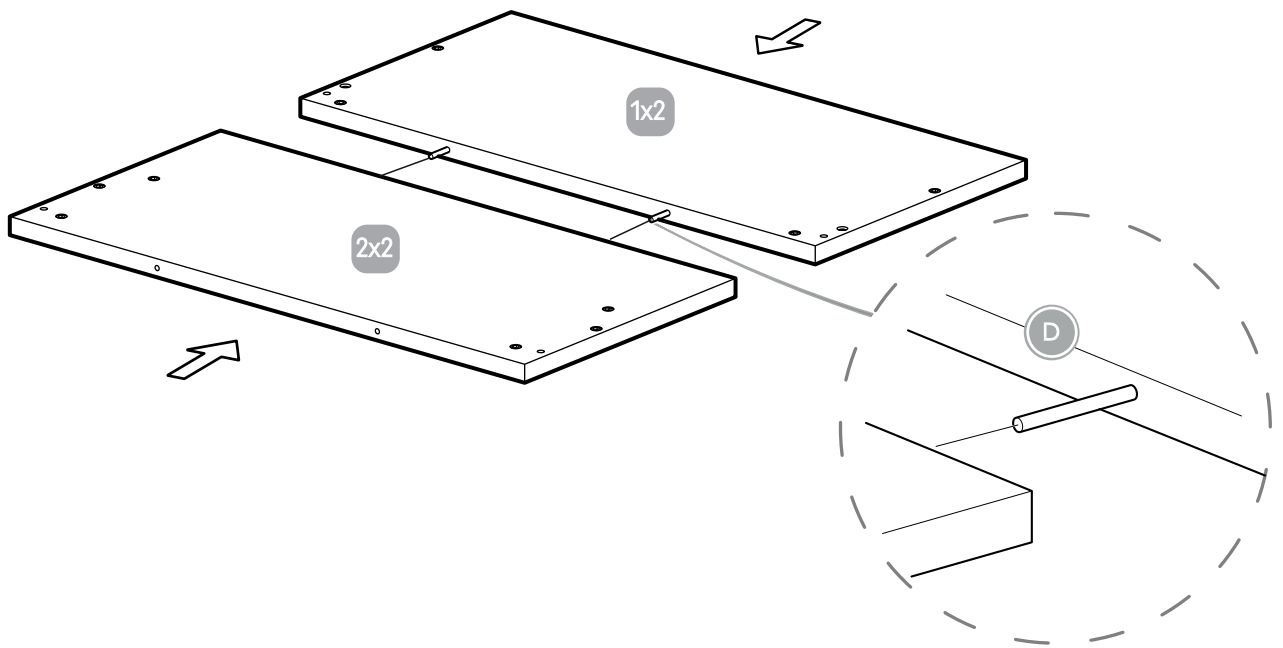
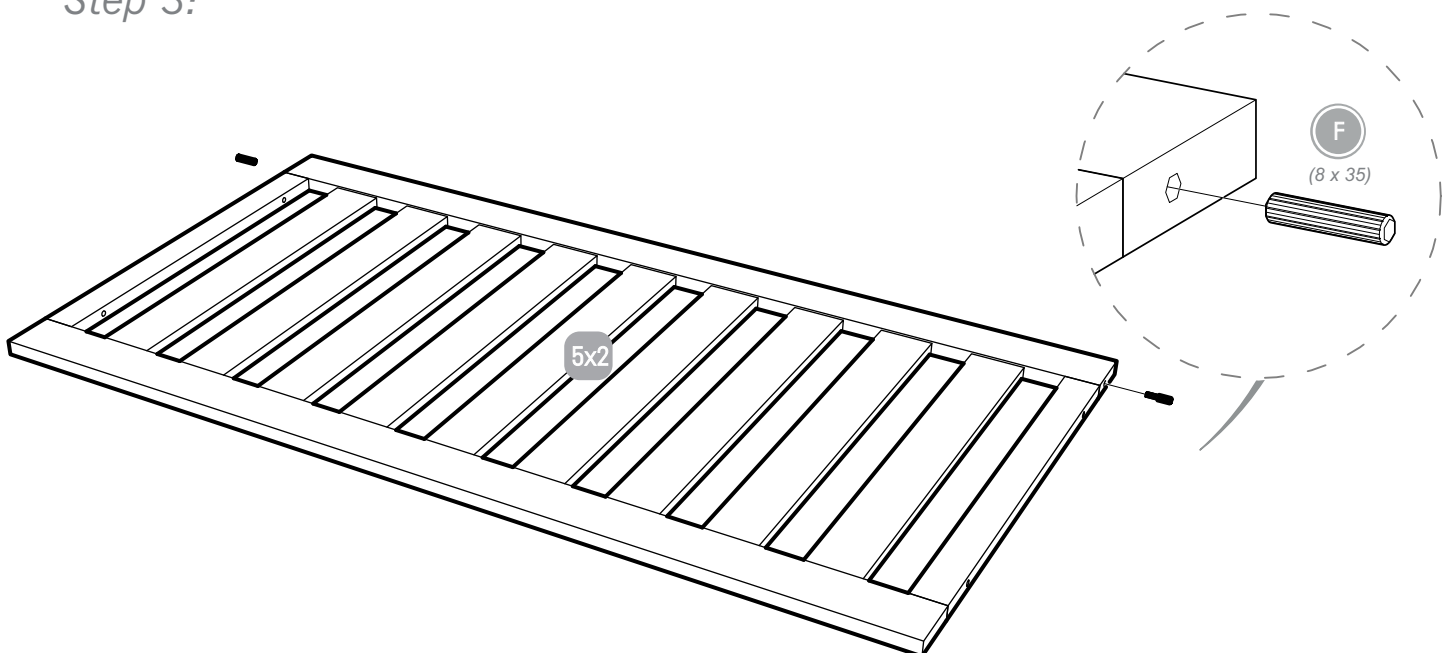
Step 1:*Step 2:**Step 3:*

Step 4:

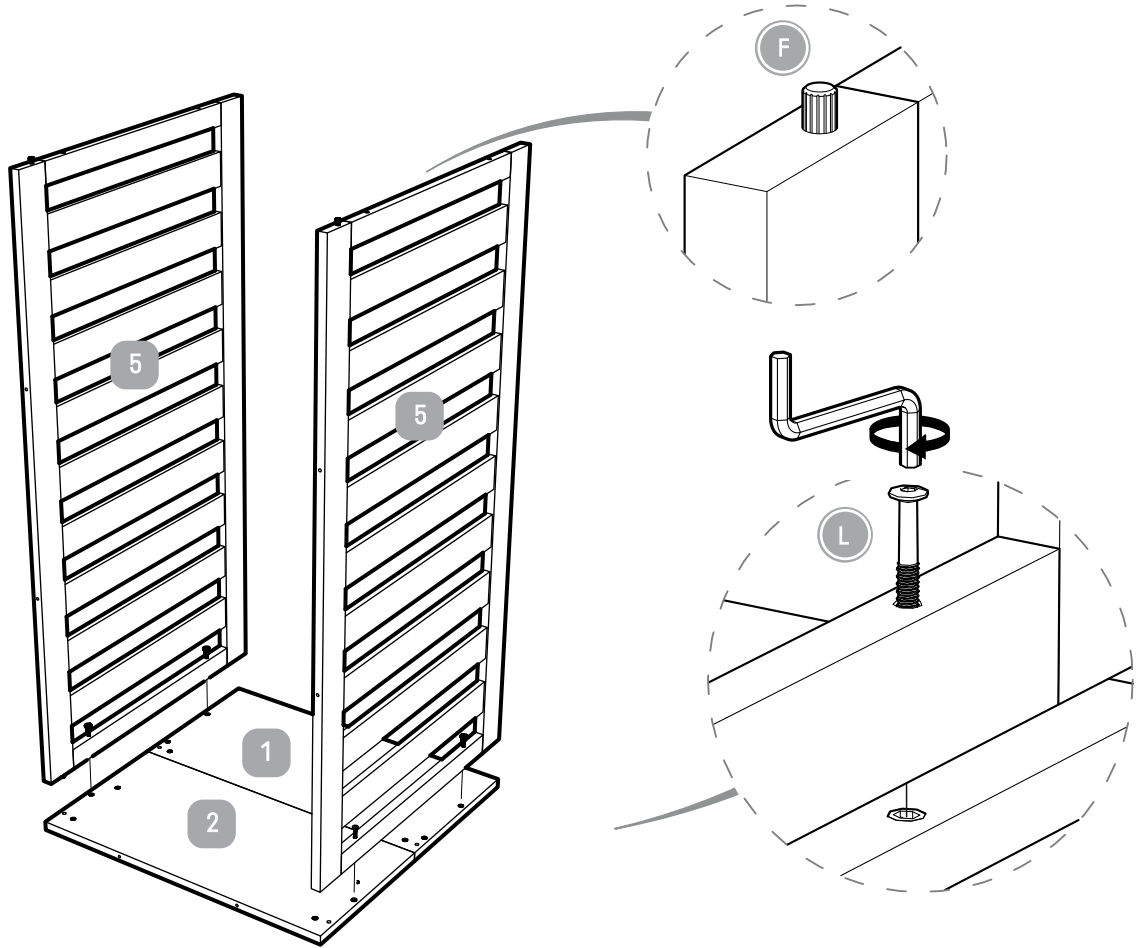

Step 5:

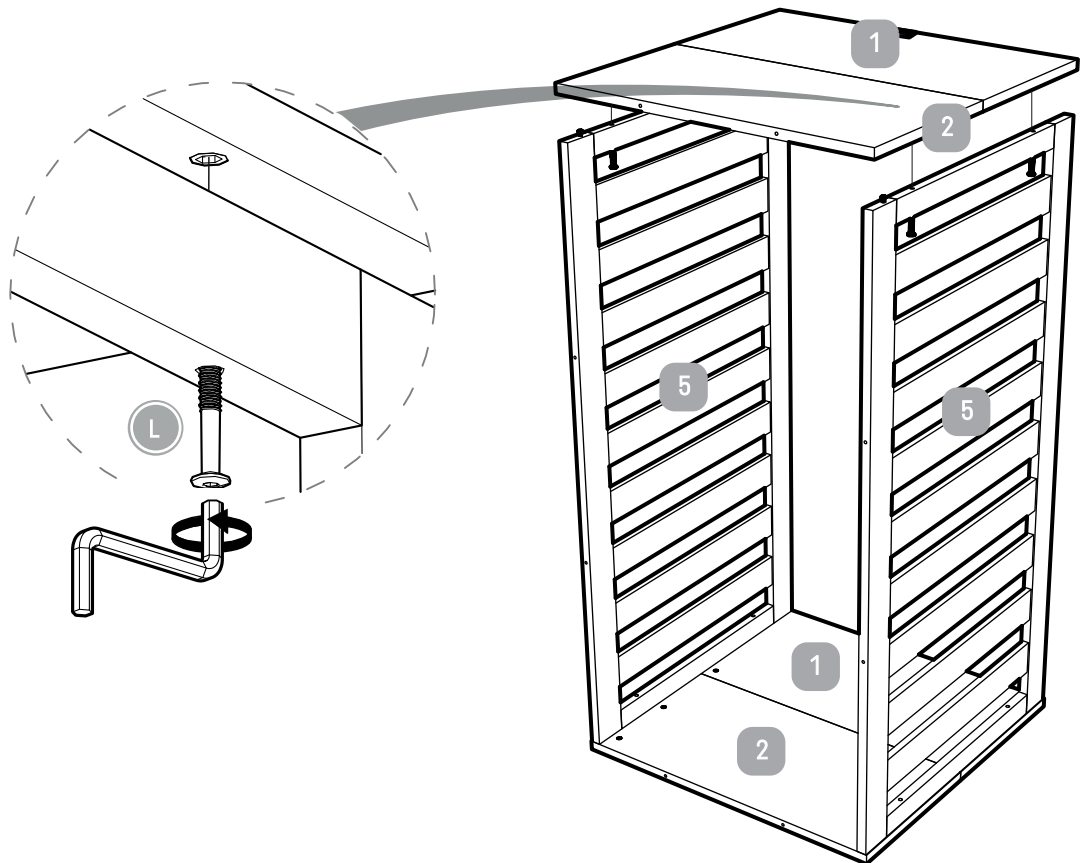

Step 6:

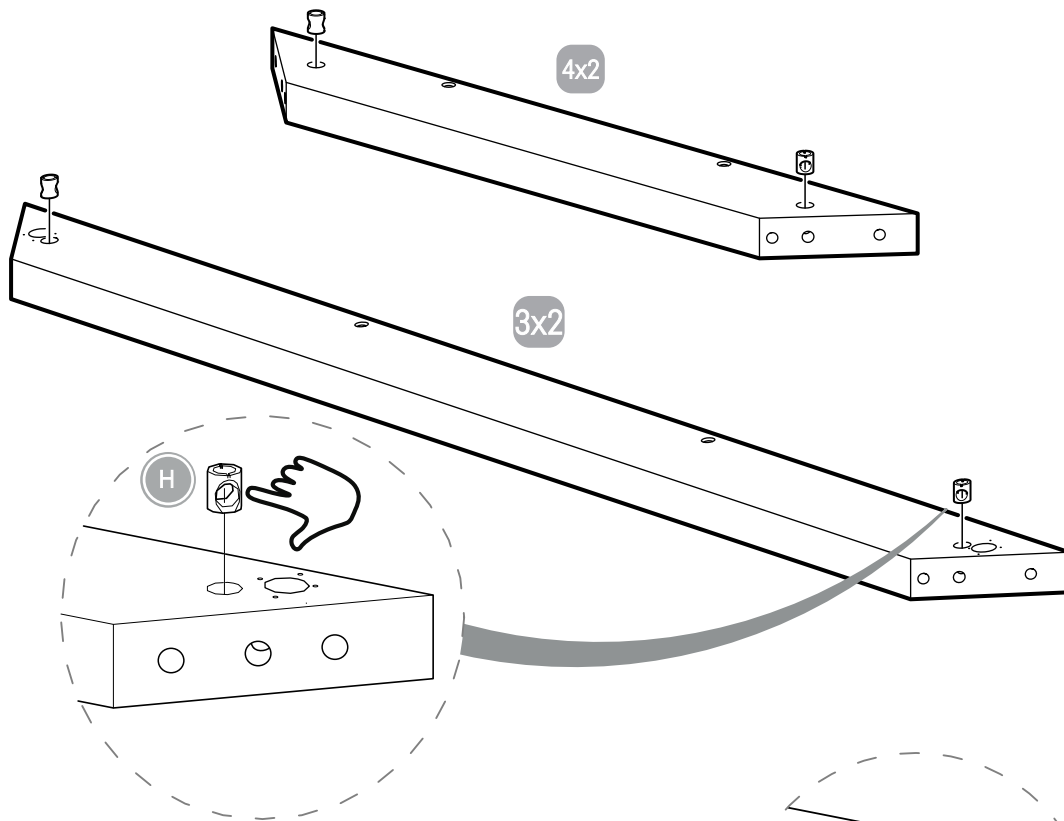

Step 7:

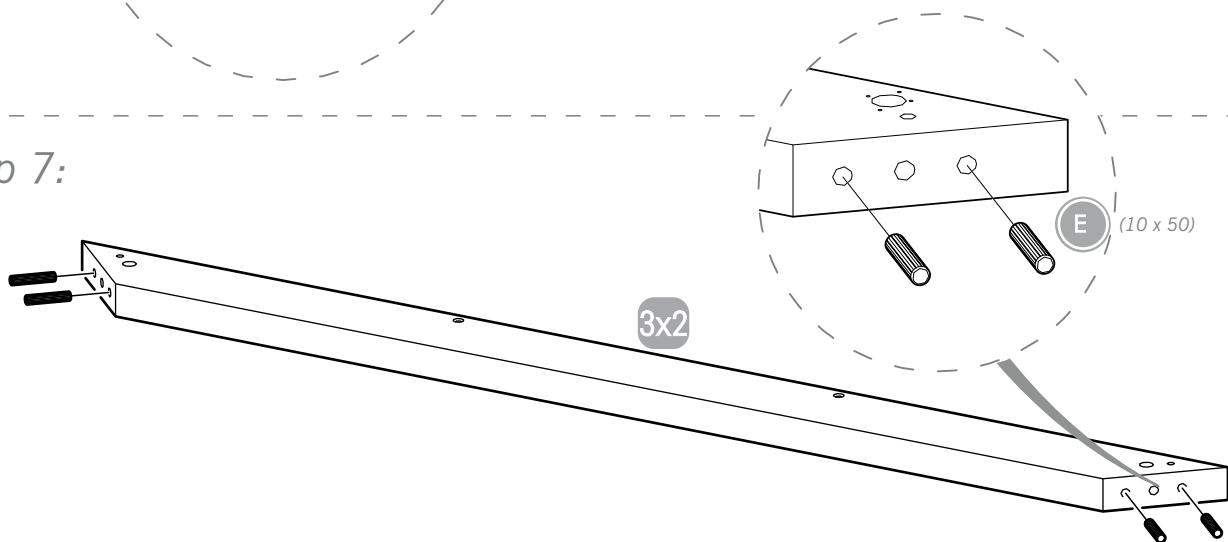

Step 8:

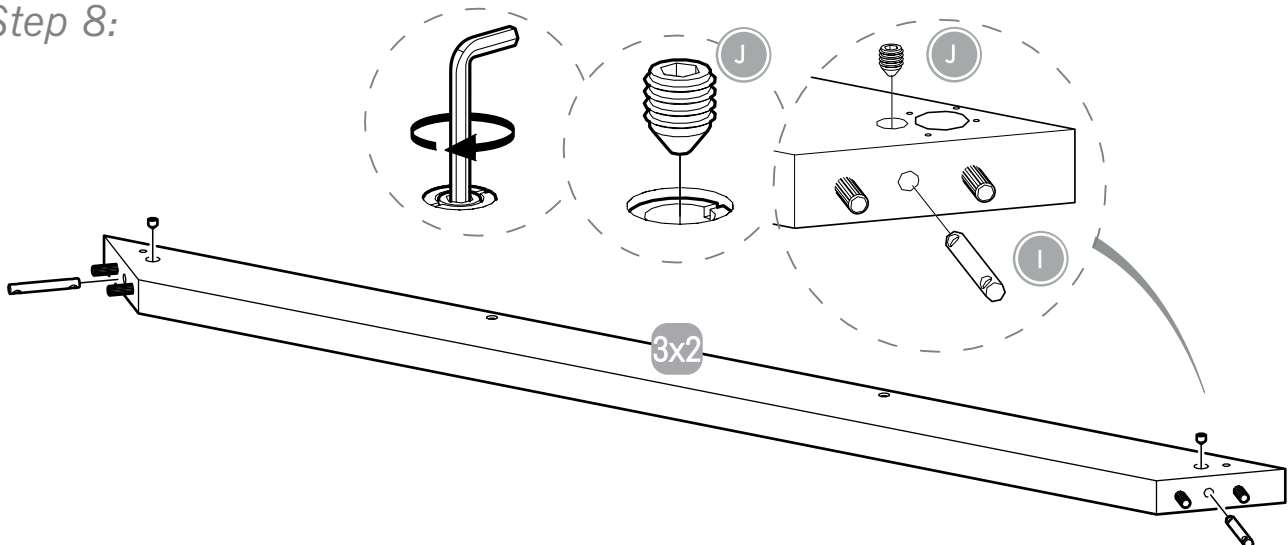

Step 9:

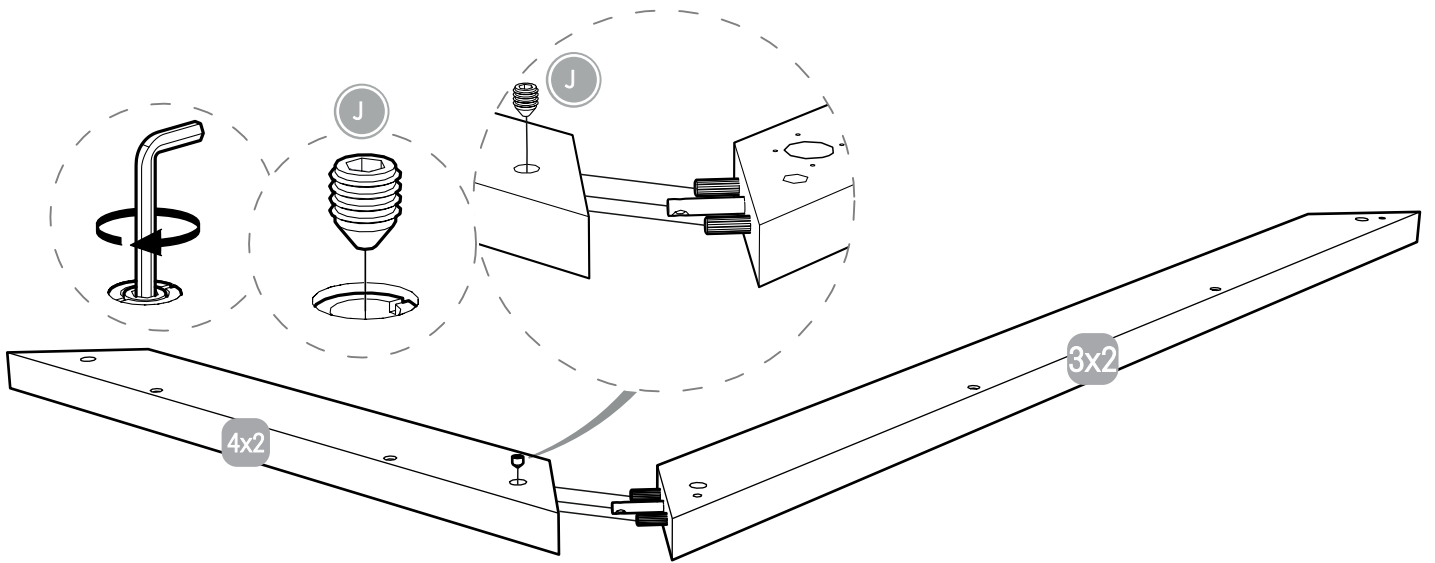

Step 10:

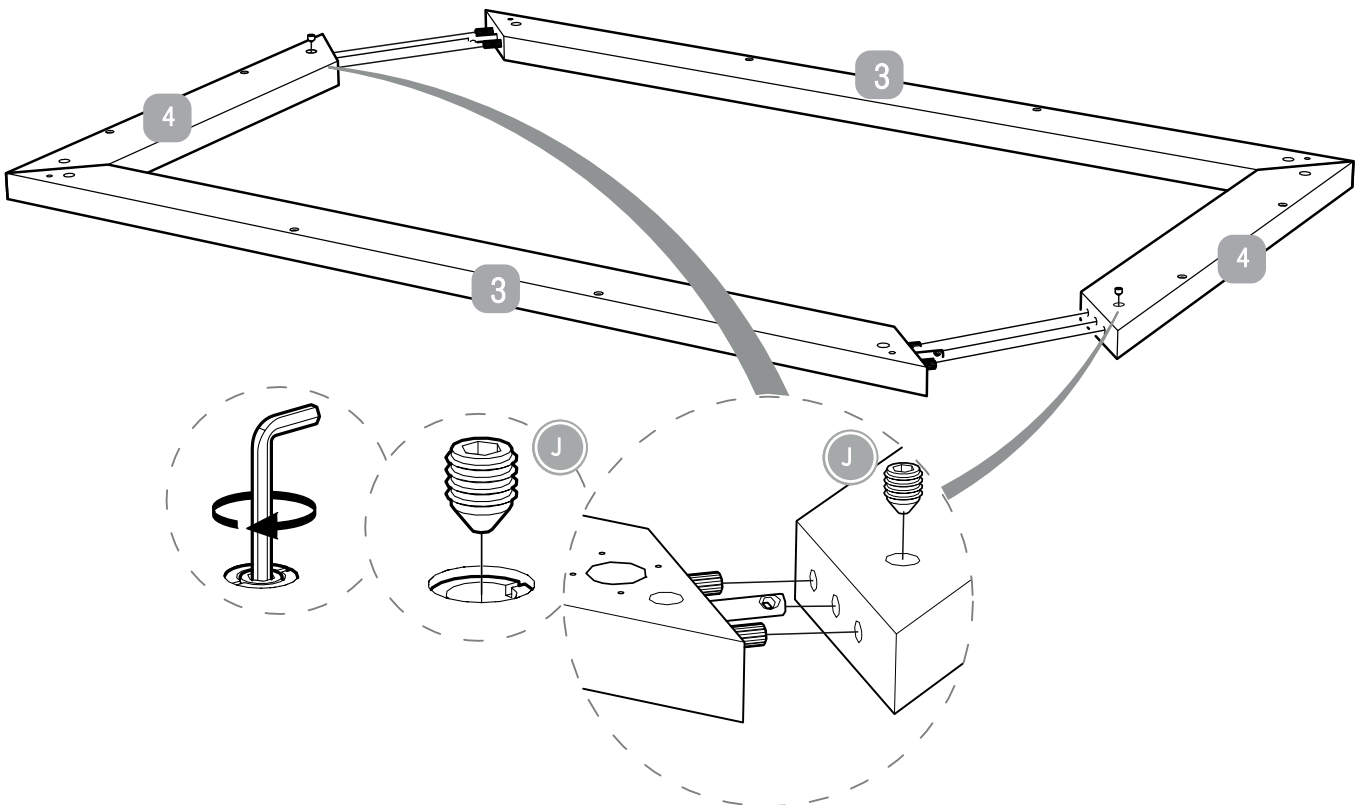

Step 11:

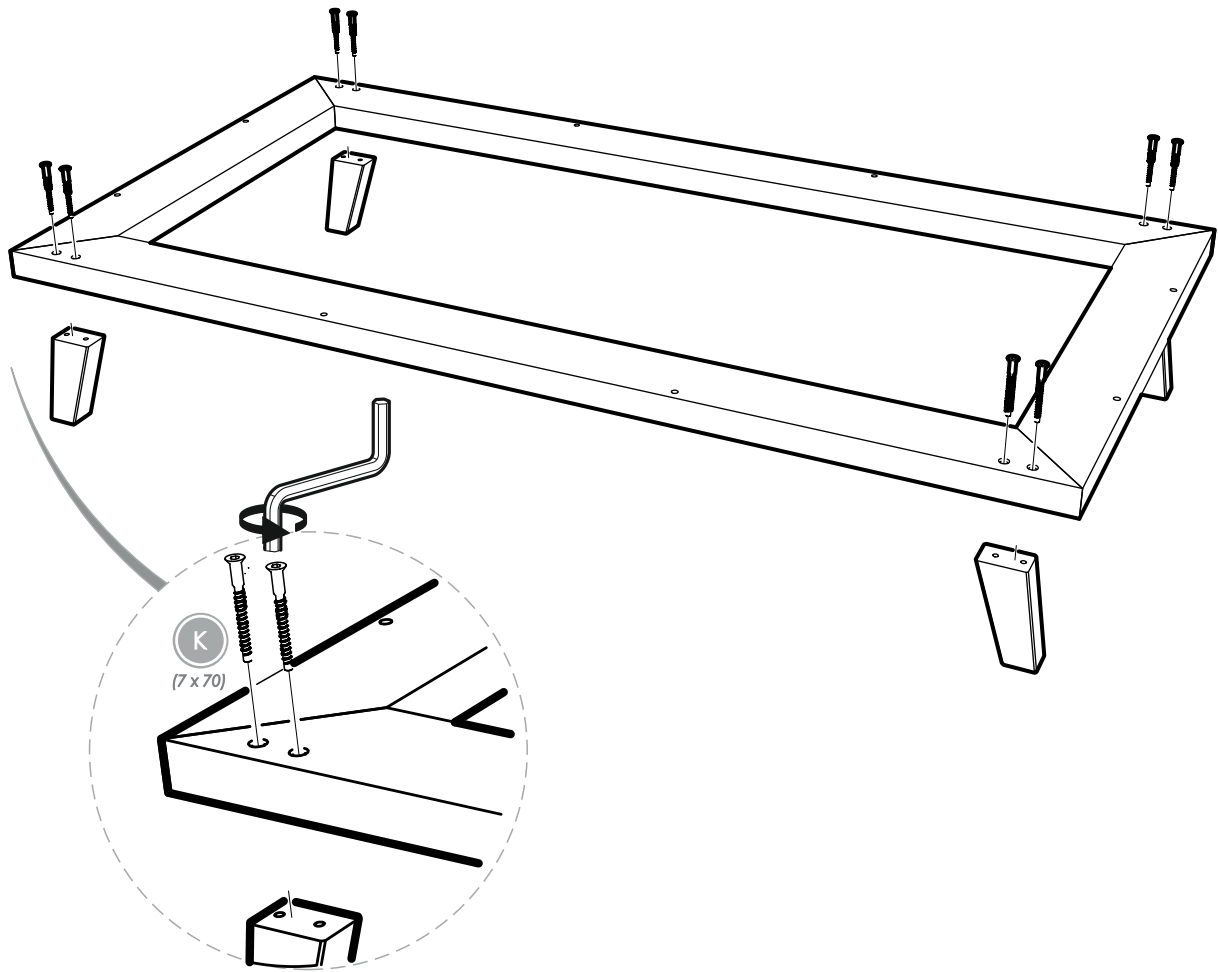

Step 12:

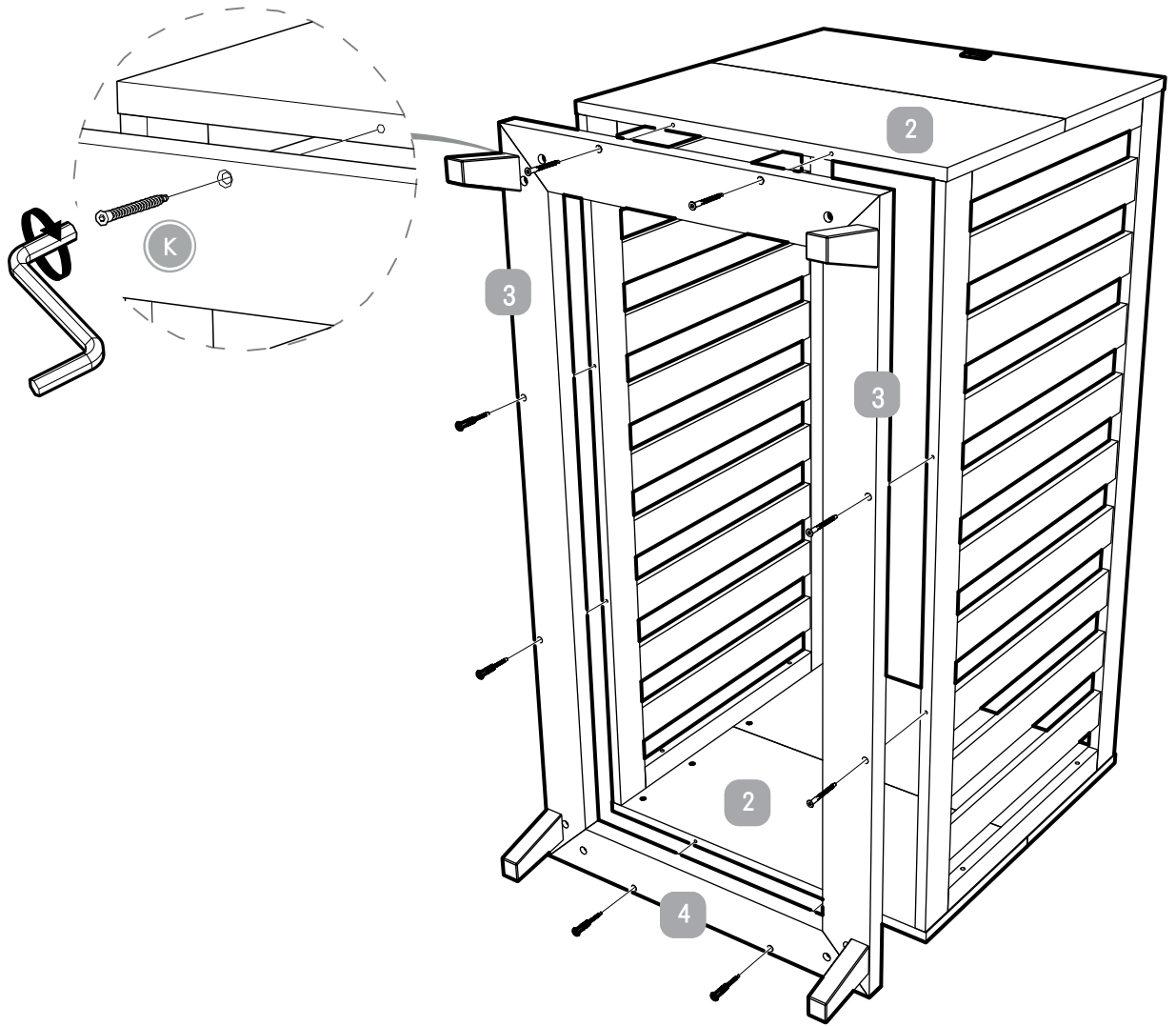

Step 13:

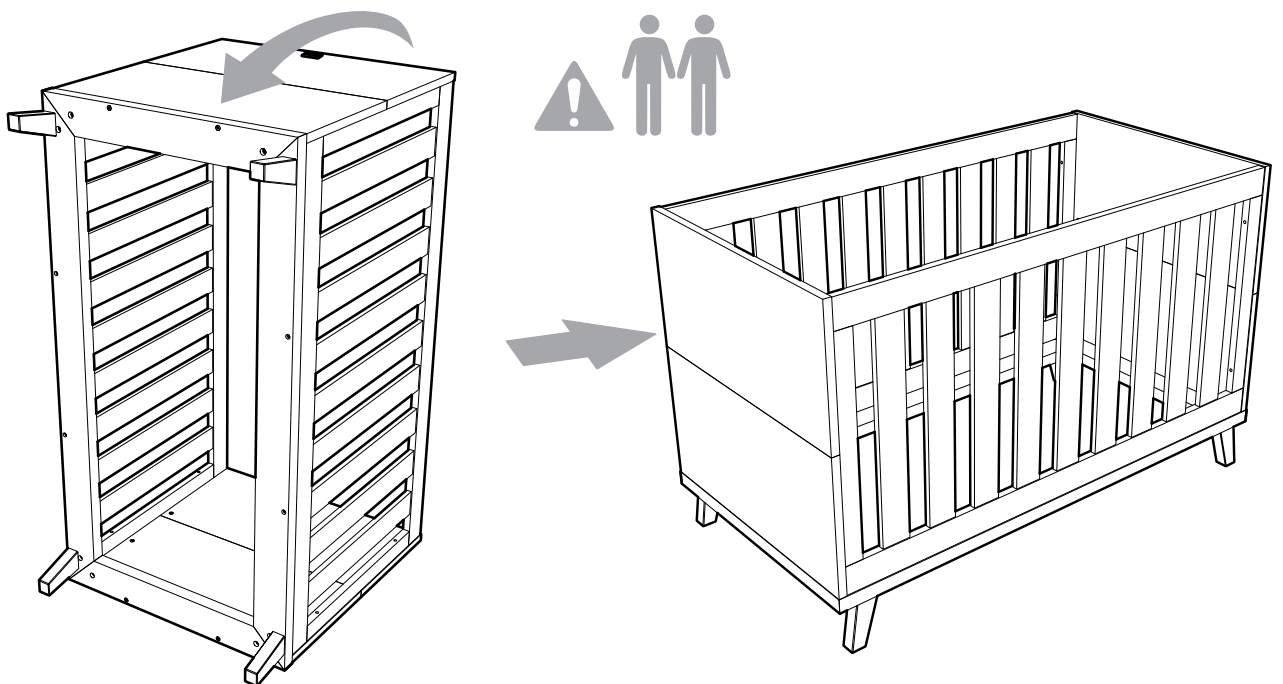

Step 14:

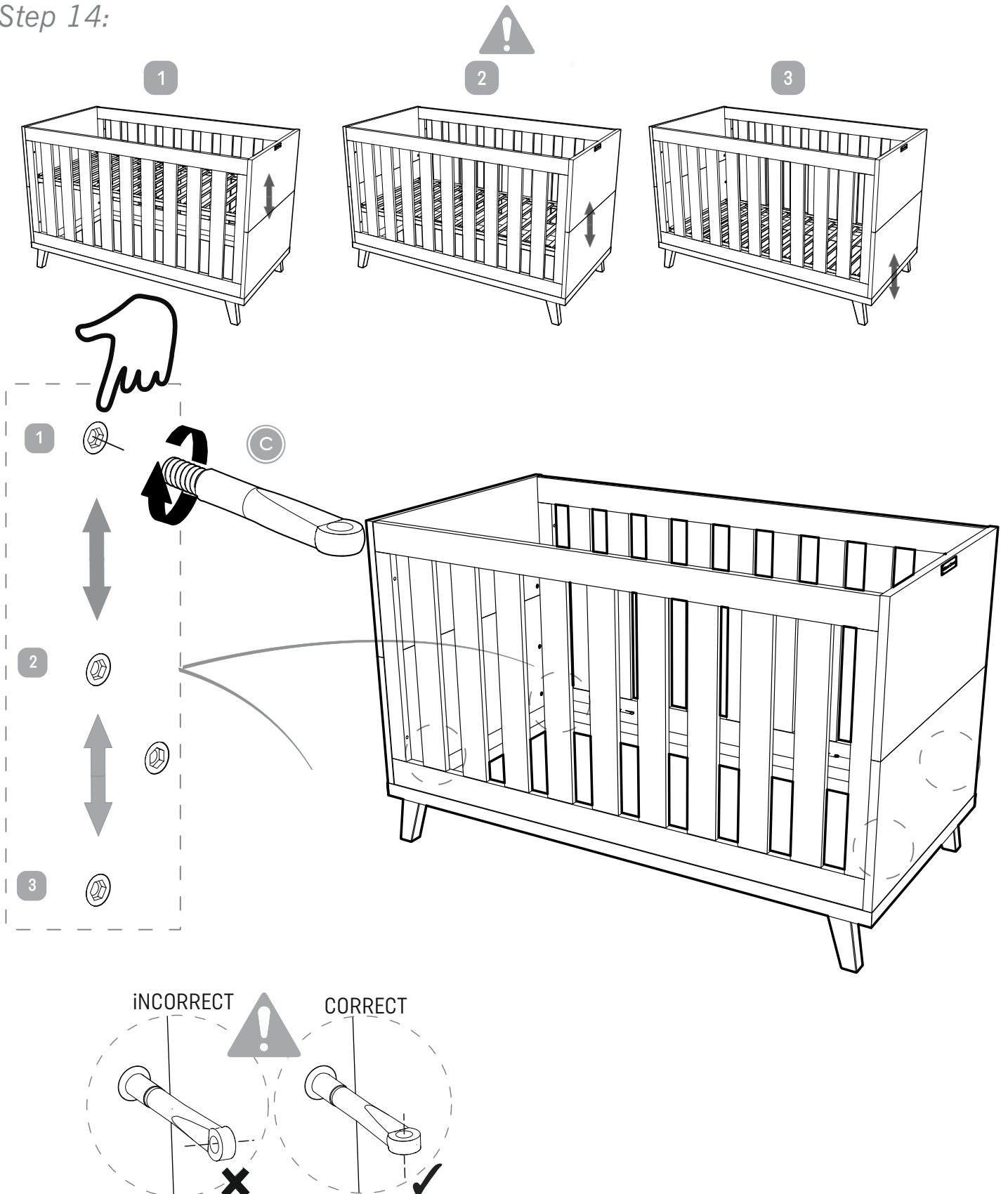

The cot bed base can be fitted at three different heights.
The lowest is the safest.

Step 15:

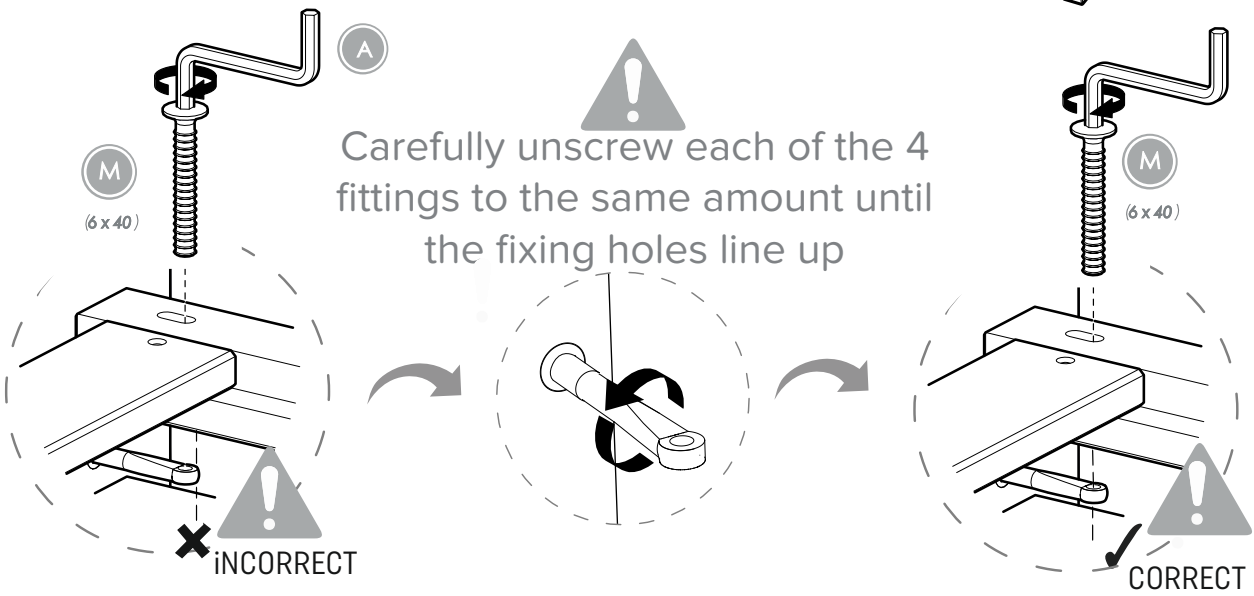
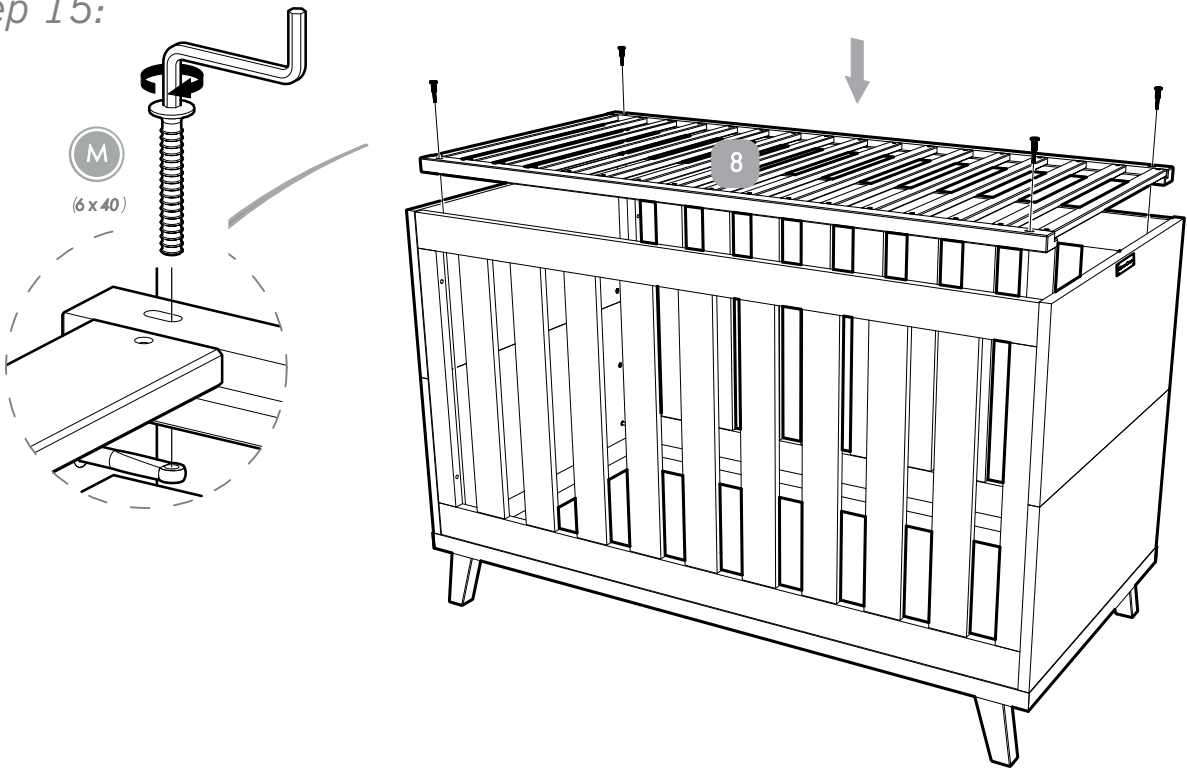

Step 16:

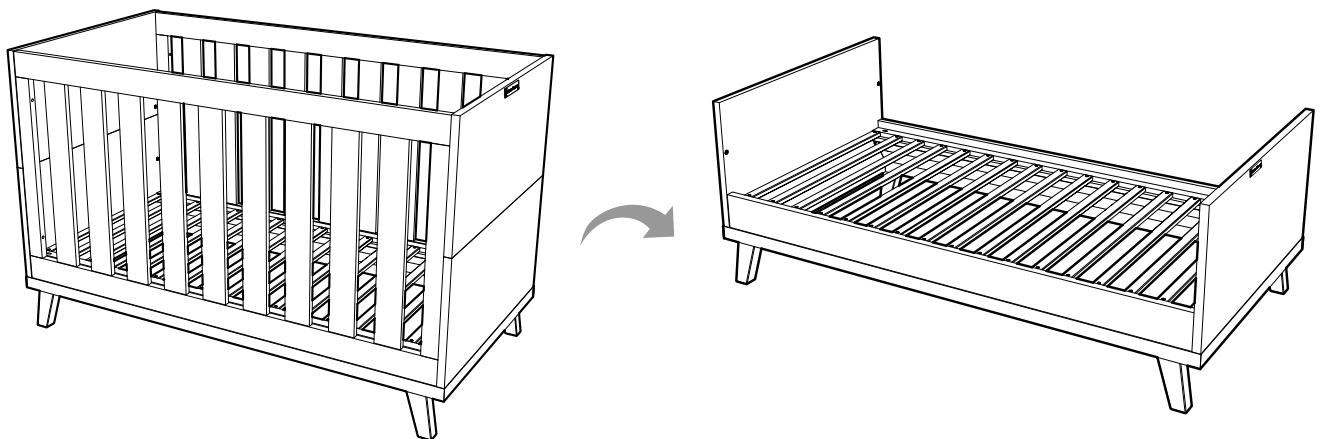

Step 17:

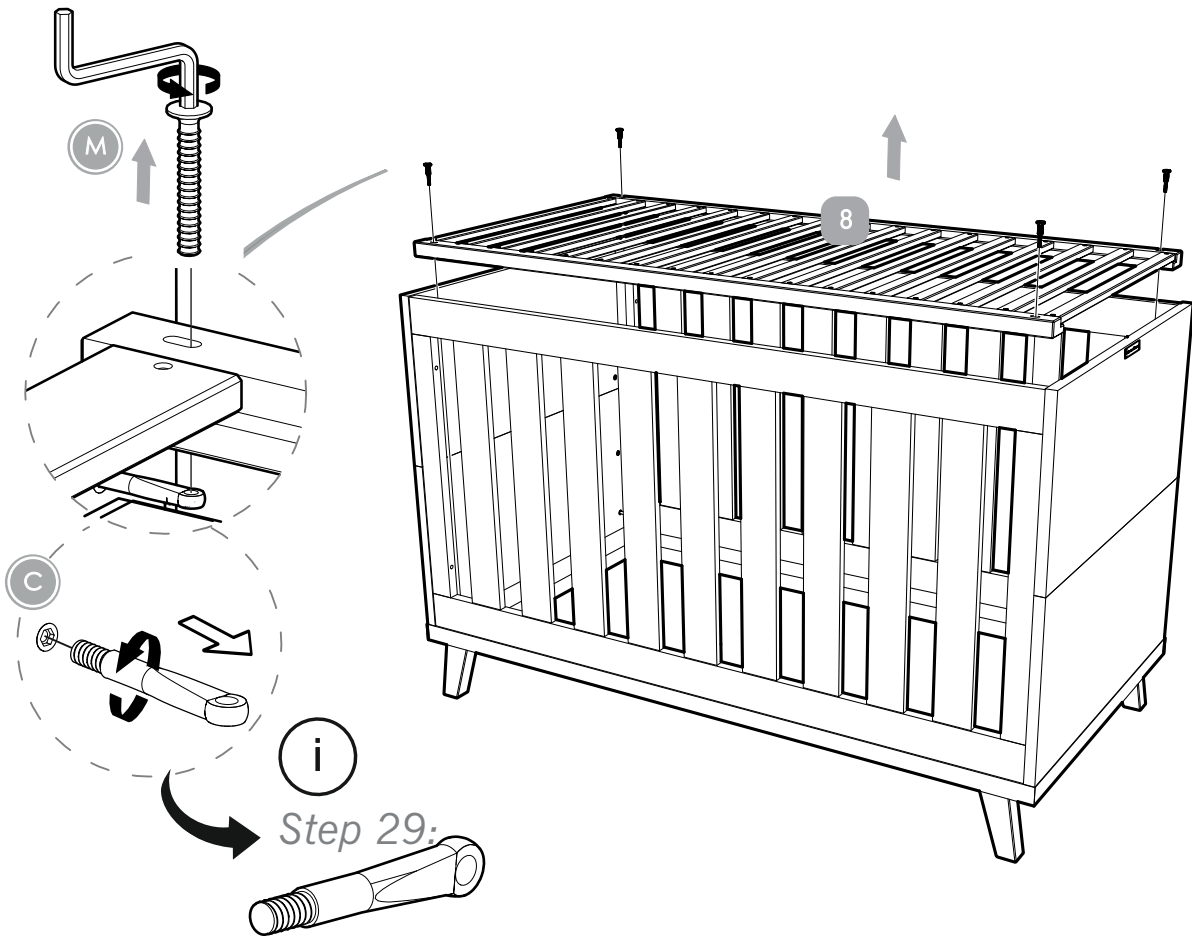

Step 18:

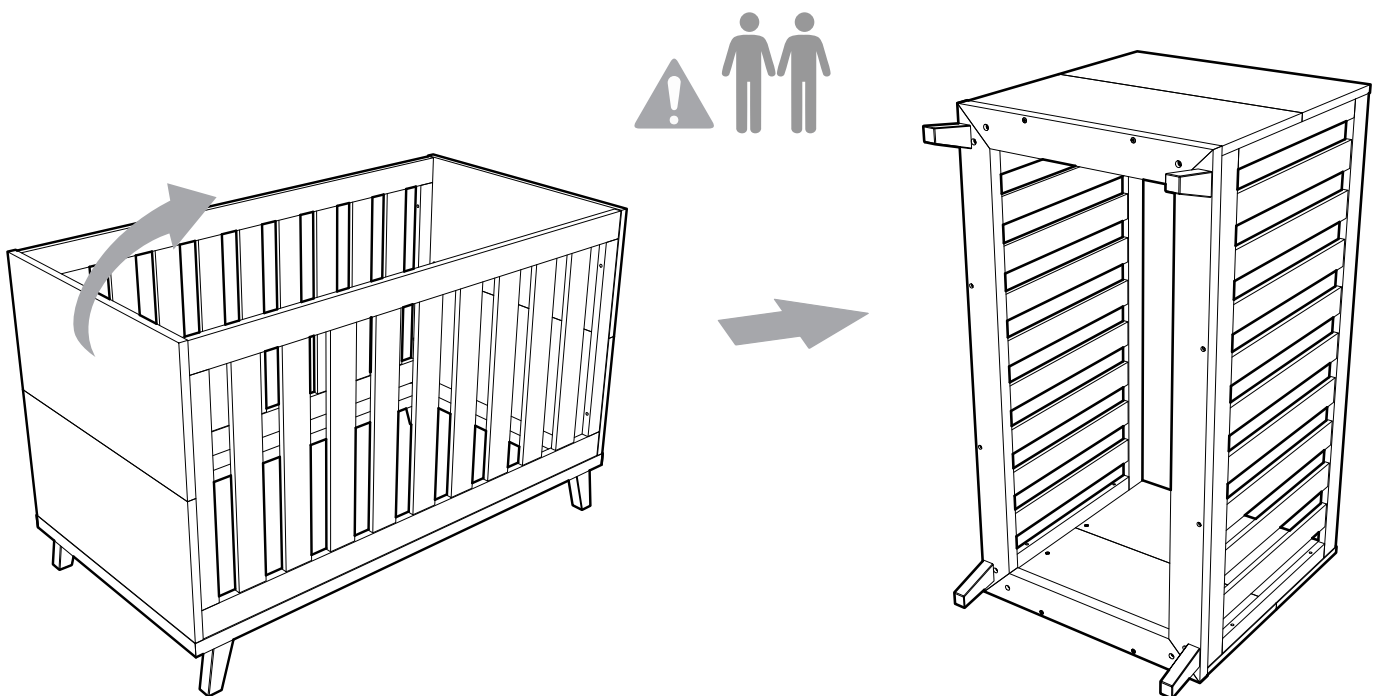

Step 19:

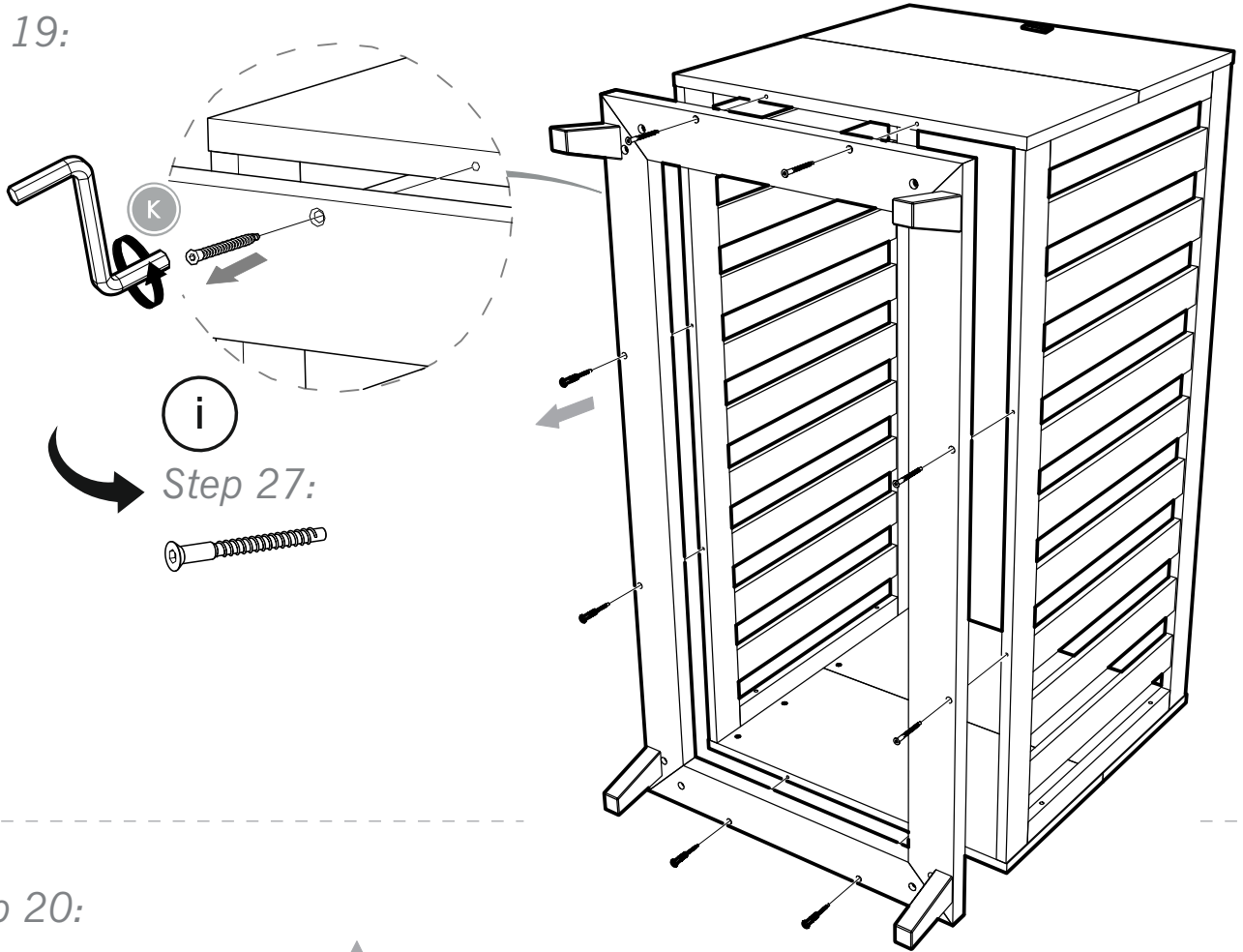

Step 20:

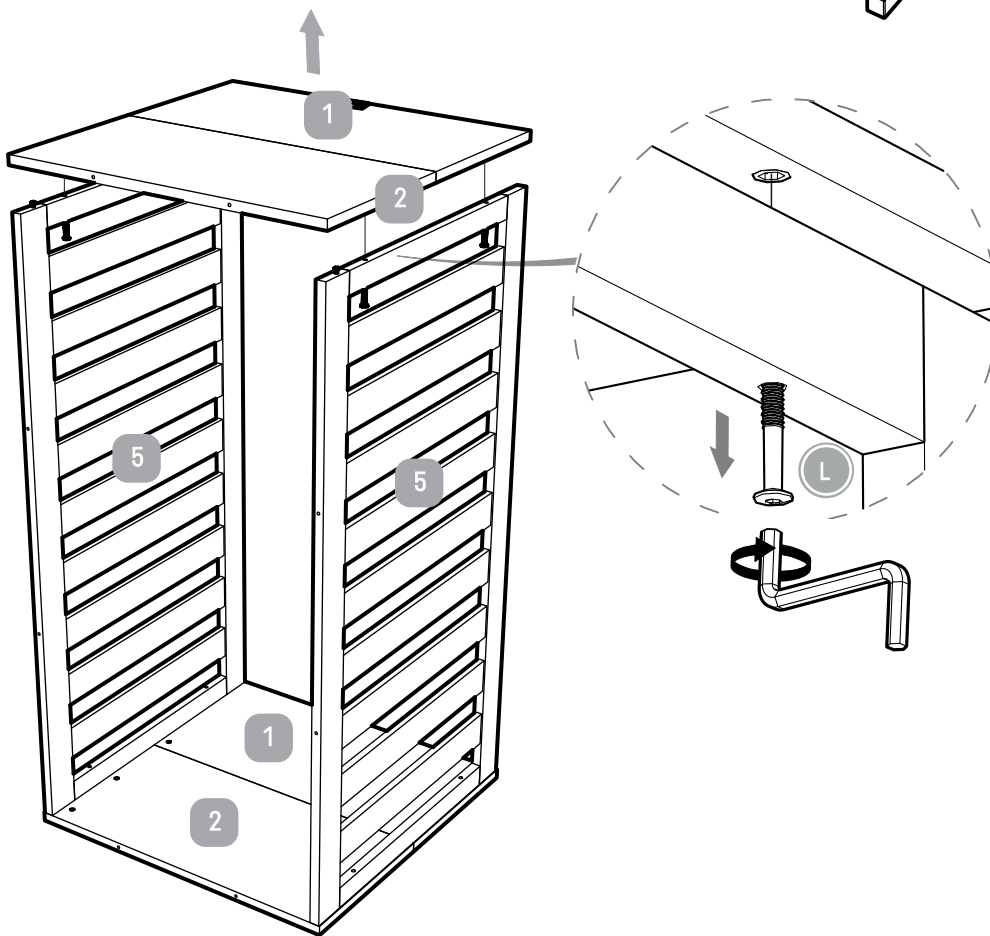

Step 21:

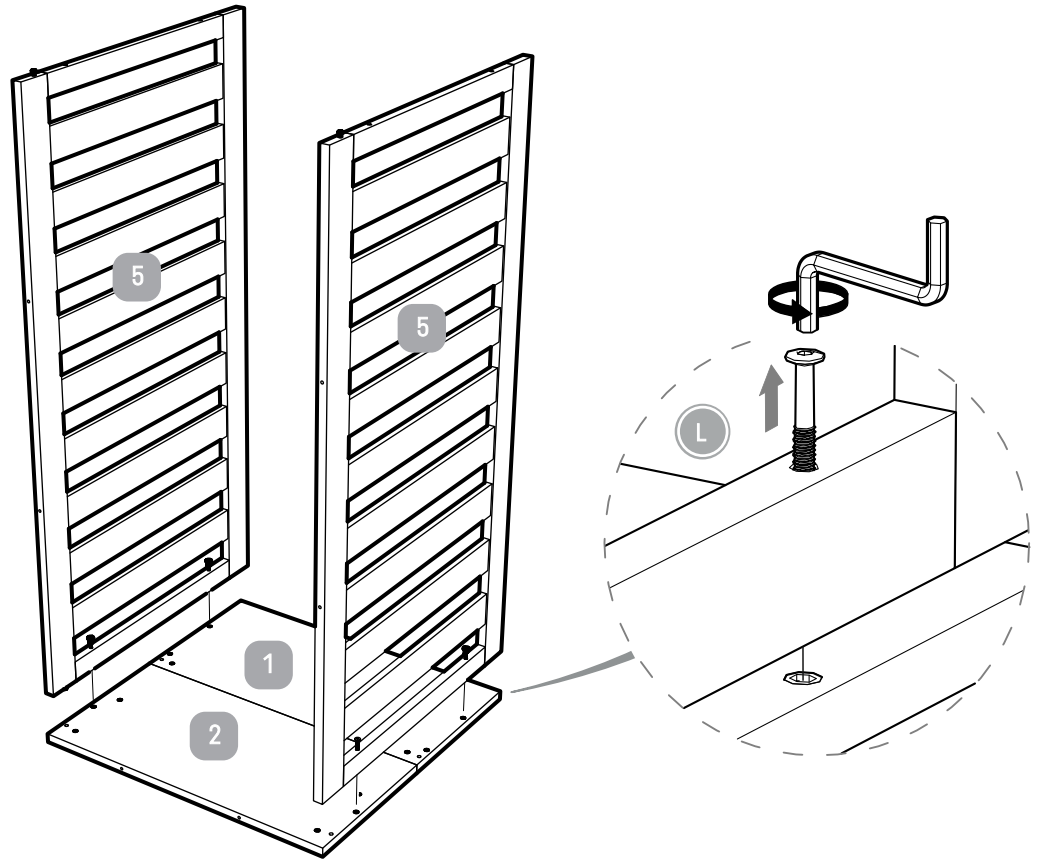

Step 22:

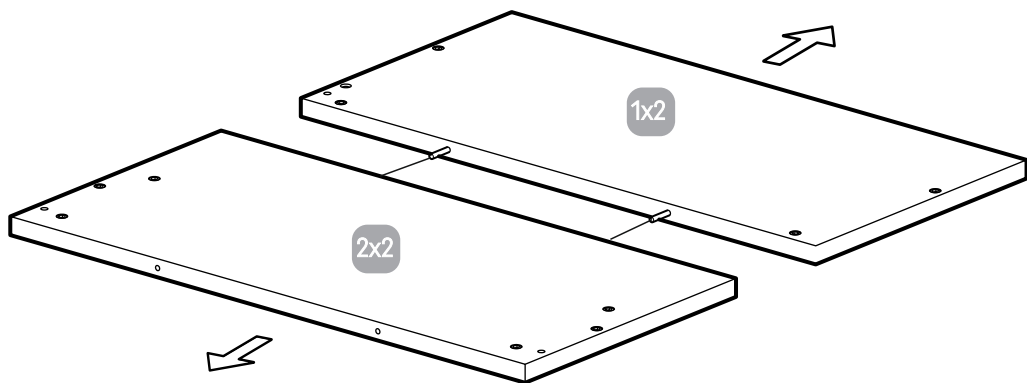

Step 23:

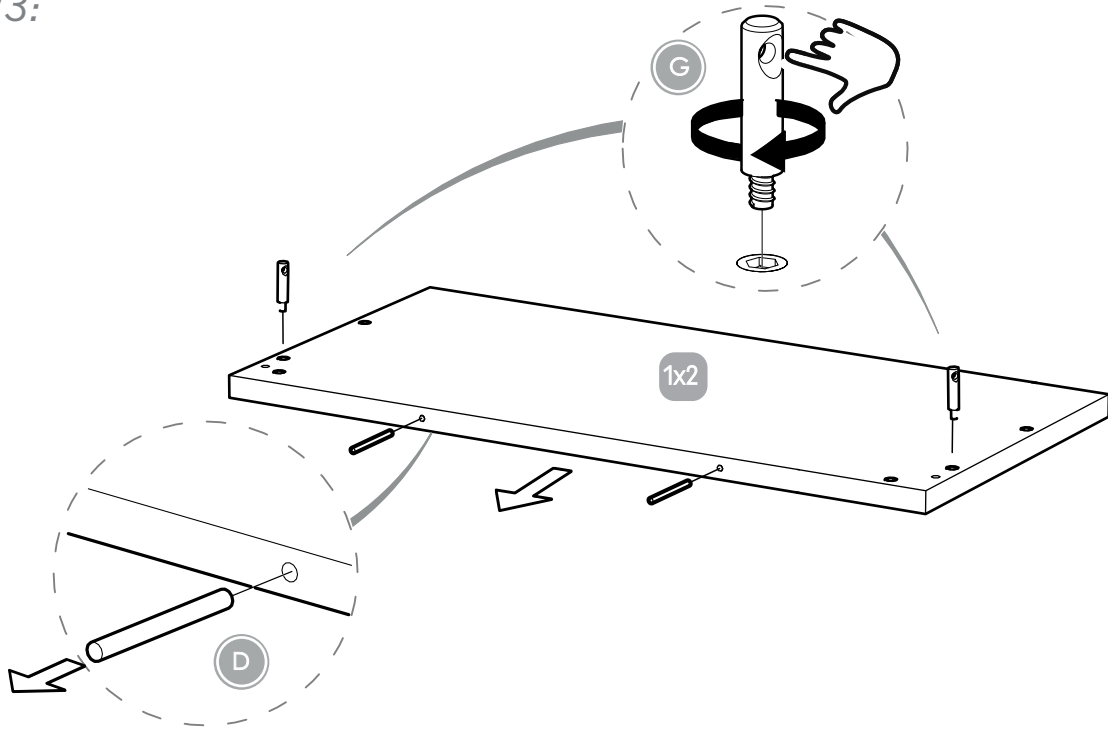

Step 24:

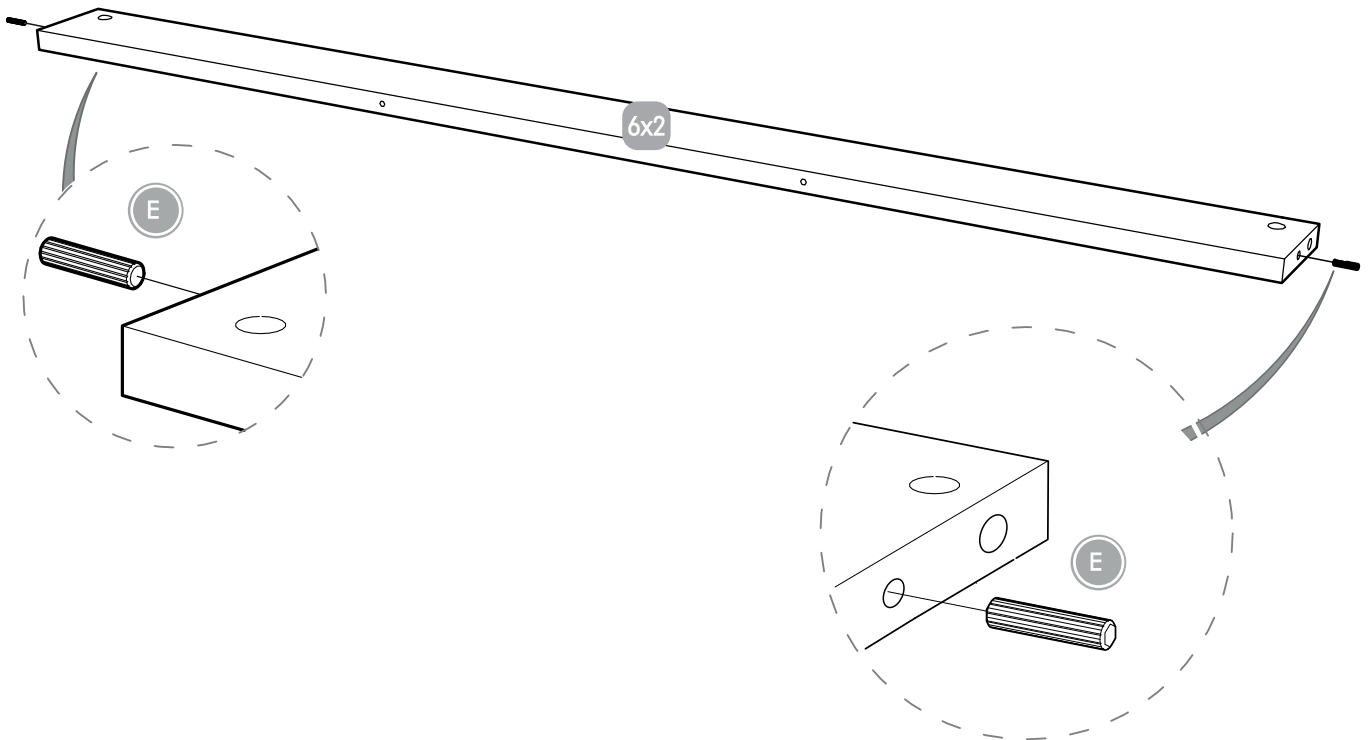

Step 25:

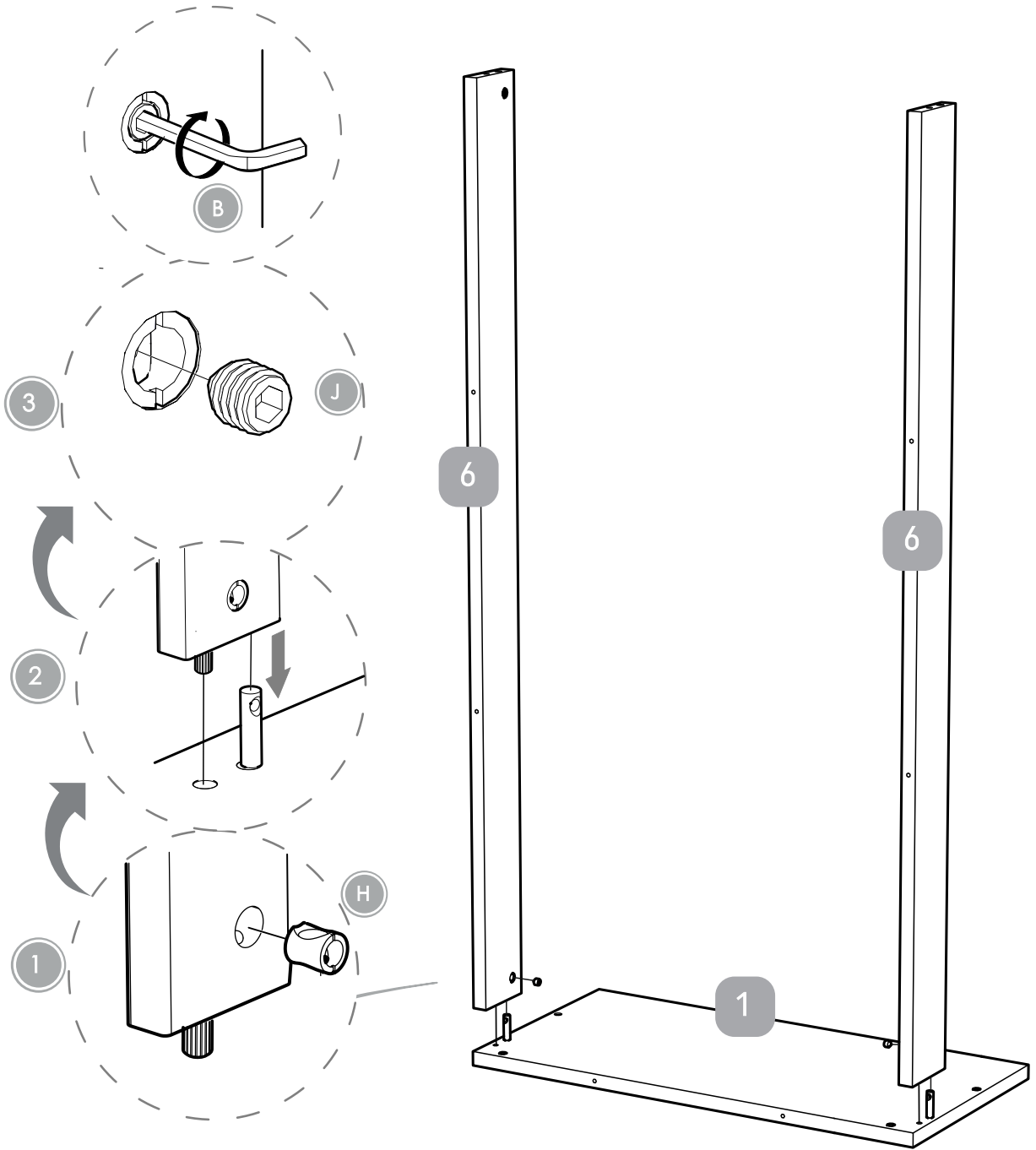

Step 26:

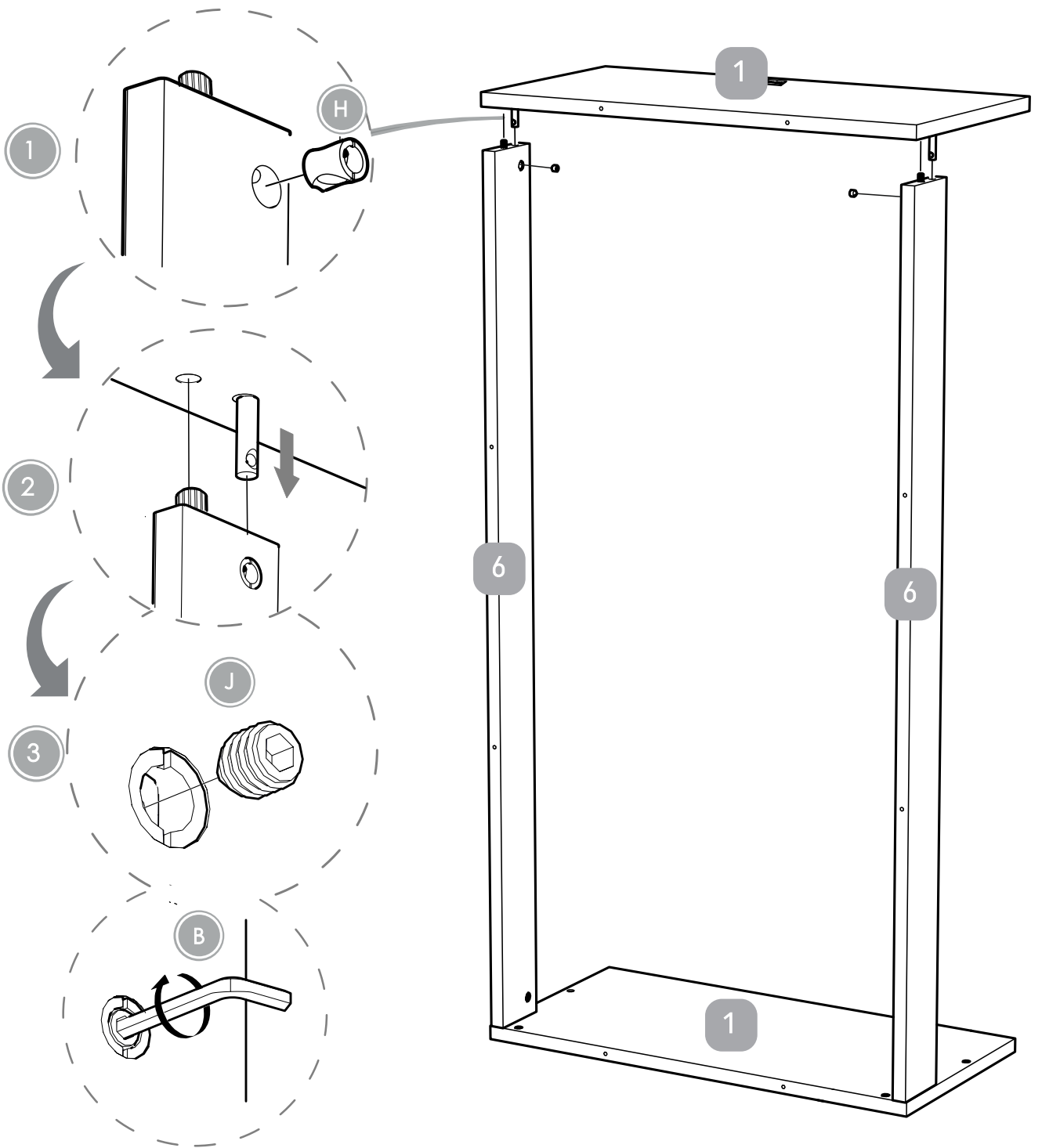

Step 27:

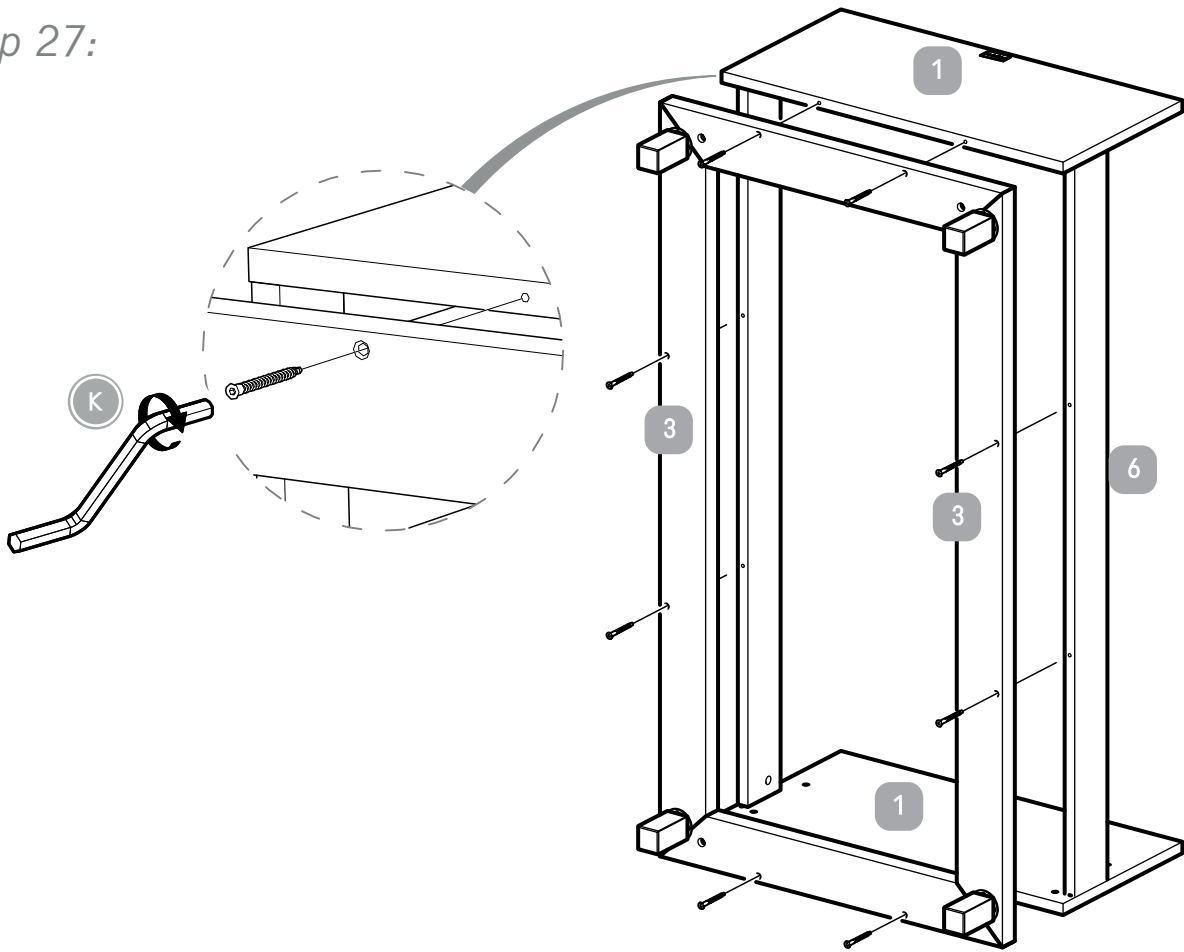

Step 28:

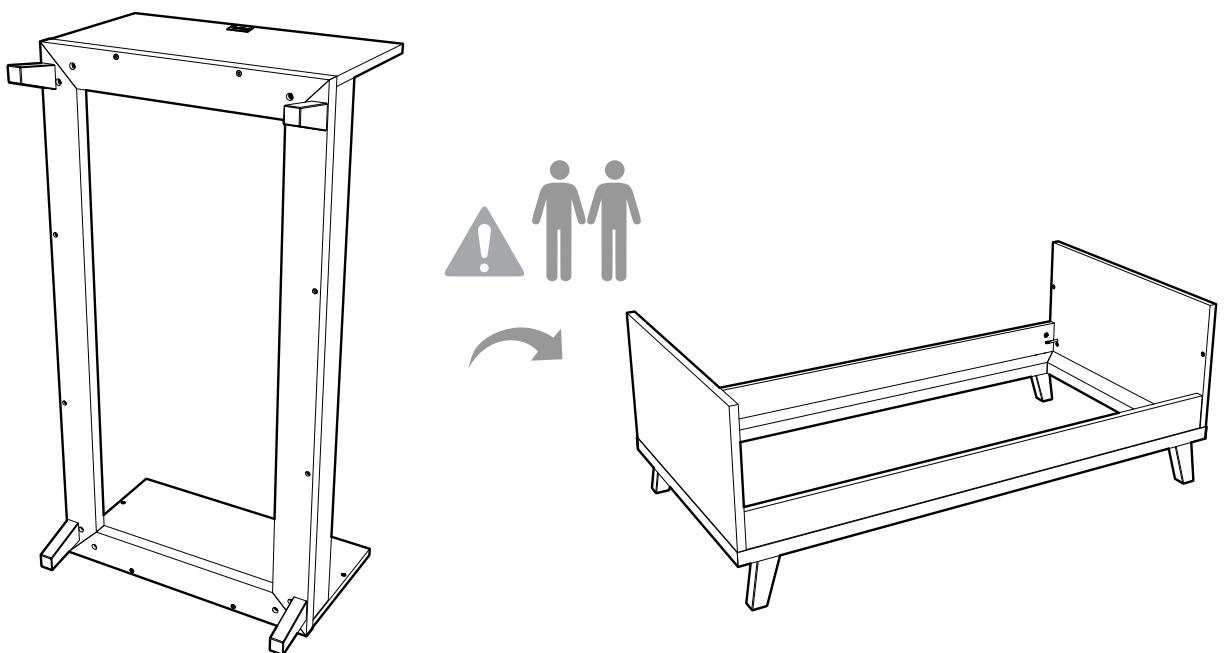

Step 29:

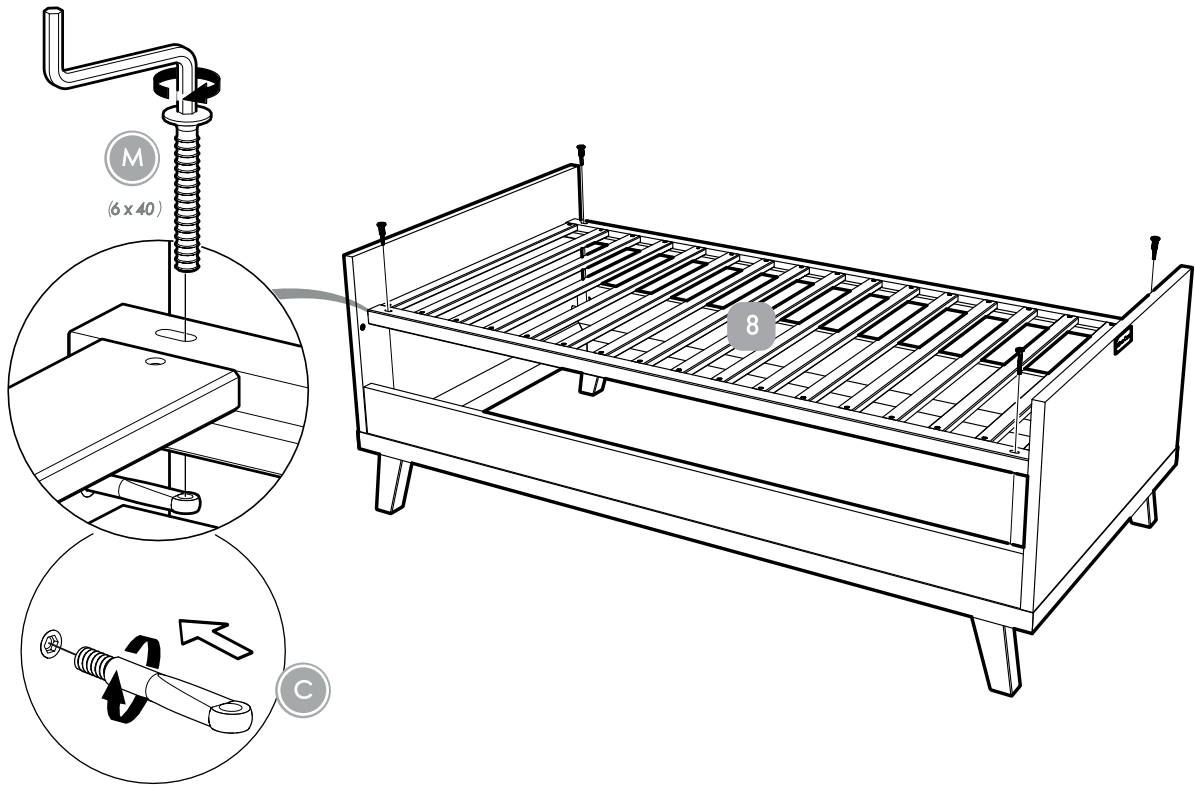

Step 30:

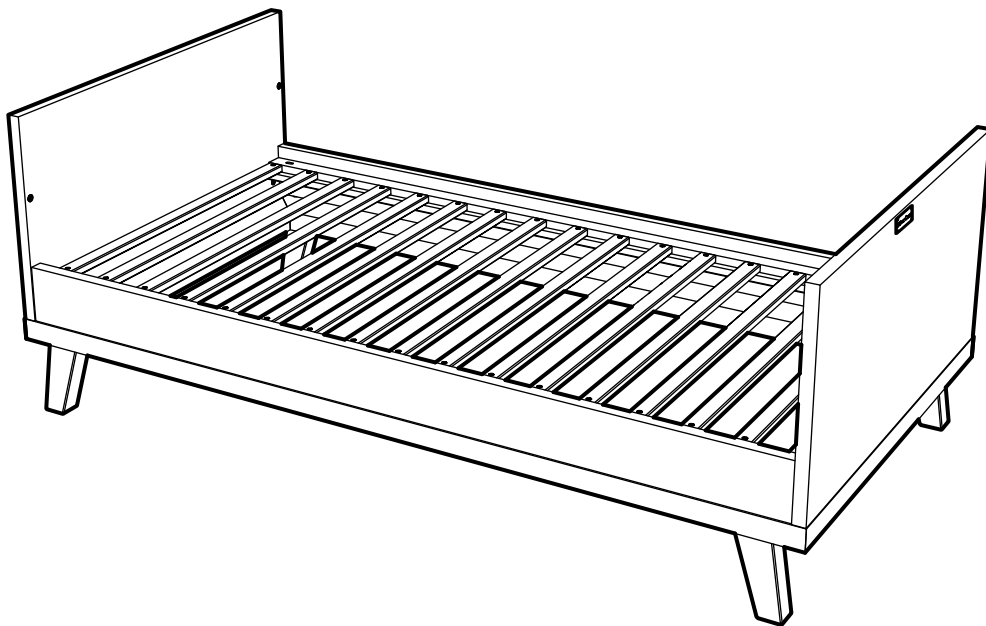

Warnings & Instructions

For Safe Use & Maintenance

WARNING: Be aware of the risk of open fire and other sources of strong heat, such as electric bar fires, gas fires etc, in the vicinity of the cot/bed.

WARNING: Do not use the product if any part is broken, damaged, torn or missing. Approved replacement parts can be obtained from Silver Cross.

WARNING: Do not leave anything in the cot/bed, or place it close to another product which provides a foothold or presents a danger of suffocation or strangulation. For example strings, blind/curtain cords etc.

WARNING: Do not use more than one mattress in the cot.

WARNING: Children are likely to play, bounce, jump and climb on beds, therefore the child's bed should not be placed too close to other furniture or windows, and should be placed either tight to any wall or have a gap of 300mm between the wall and the side of the bed.

WARNING: Do not place this child's bed near heat sources, windows and other furniture.

The lowest position of the mattress base is the safest, and should be used as soon as the baby is old enough to sit up. To prevent injury from falls, when the child is able to climb out of the cot, the cot shall no longer be used for that child.

Thickness of the mattress chosen must not reduce the internal depth (from mattress surface to top of the side) to less than 500mm with the base in its lower position or 200mm with the base in its higher position.

Maximum 10cm thick mattress to be used with this cot bed.

If you leave the child unattended in the cot, always make sure that the dropside is in the highest position.

All assembly fittings should be tightened properly, checked regularly and re-tightened as necessary.

Screws and bolts should not be loose because a child can squeeze parts of the body, or clothing e.g string, necklaces, ribbons for babies dummies etc. could get caught. There would be a danger of strangulation.

The cot/bed must be used on a level and stable surface, away from electric sockets. Once assembled do not dismantle. Never move the cot/bed with a child in it.

Excessive chewing may damage the wood and cause splintering. If any part is damaged stop using until the correct replacement part has been obtained from Silver Cross.

Your cot/bed can be cleaned by wiping with a damp cloth and drying immediately with a soft clean cloth.

Do not use abrasives, bleach, alcohol or ammonia based household polishes.

Take care when handling or moving furniture, careless handling can damage wooden furniture.

Wood is a natural material, the colour will darken with age.

The size of the mattress to be used with the child's bed is 1400x700mm.

Cot conforms to BS EN 716-1/2:2017 and toddler bed to BS 8509:2008+A1:2011.

Cots which convert to toddler beds are intended from birth up to approximately 4 years.

The mattress length and width shall be such that the gap between the mattress and the sides and ends does not exceed 30mm.

The logo for Silver Cross, featuring the brand name in a stylized, cursive font.

Silver Cross (UK) Ltd, Micklethorn, Broughton, Skipton, North Yorkshire, BD23 3JA

silvercrossbaby.com

IND.1129917

IM-CMB-220517-01r01